



VG LED Series



Description

The **VG LED (VGL) Series** is a non-metallic LED luminaire specifically designed to reduce energy usage without sacrificing lumen output, for use in harsh and wet environments where constant humidity or moisture is present. The **VG LED (VGL) Series** is comprised of a heavy-duty one-piece housing and a high impact resistant lens, which is held in place on a poured-in, closed-cell gasket by polycarbonate or stainless steel captive latches. The **VG LED (VGL) Series** is available in 2', 4' and 8' lengths with medium or high output lumen package options. Food processors, breweries, dairies, parking garages, and car washes are just a few areas that can benefit from the **VG LED (VGL) Series**.

Dimensions

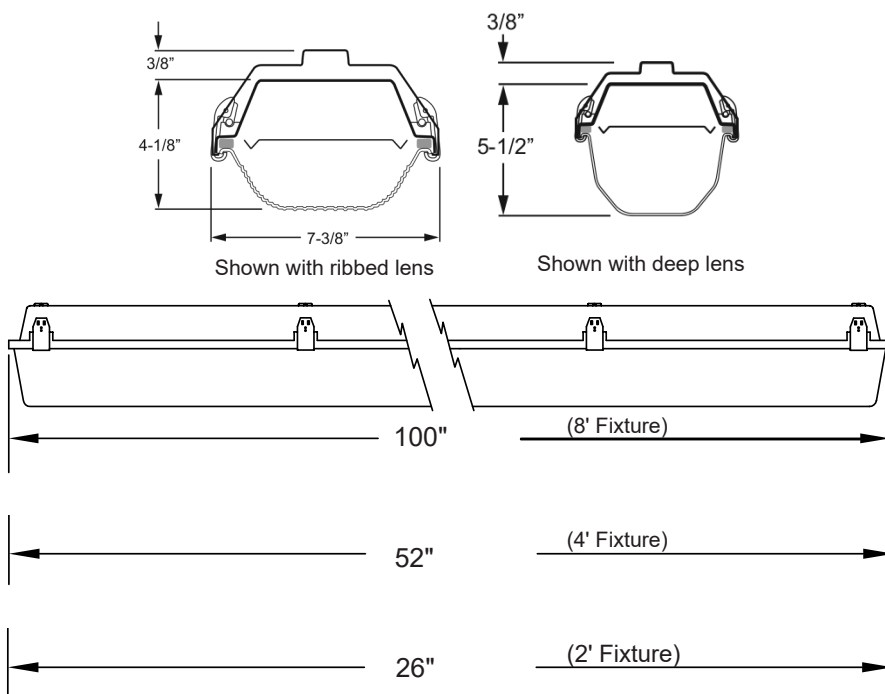

Date	Catalog #
Type	Project
Prepared by	Comments

Features and Specifications

ENCLOSURE

Fiberglass reinforced polyester housing is UL 5VA flammability rated. Smooth water shed design allows for easy clean up during high pressure hose down. Poured-in-place continuous closed cell gasket provides a seamless seal for the lens, which resists dust and moisture.

LENS

Precision molded, high impact deep frosted acrylic lens is held in place with easy-to-install injected molded polycarbonate latches or optional stainless steel captive latches. Ribbed and clear lenses also available.

GEAR TRAY

The inherently rust resistant aluminum gear tray provides efficient heat transfer and is held in place by internal stainless steel clips and retaining straps.

ELECTRICAL

Universal Voltage (120V – 277V), constant current, Class 2 driver. High quality, mid-power LED boards rated at 50,000 hours. Component based for easy maintenance. Consult factory for all available configurations.

MOUNTING

Stainless steel mounting brackets allow for "drill free" mounting. Hanger bushing (bail) also available.

CERTIFICATIONS

- ETL listed UL 1598 for Wet Location
- ETL listed UL 1598 for Battery Back-Up
- ETL listed CSA Std C22.2 No. 250.0
- NSF Certified
- IP65, IP66, IP67 Certified
- NEMA 4X Certified
- High Pressure Tested at 1500 PSI

Warranty

- 5-year limited warranty.
(See LEI's LED Warranty for complete details.)

All dimensions are approximate and may change at the discretion of LEI.

Ordering Information

Example Catalog Number – VGL8-H45-85-U-DF-P

VGL	8	H	45	85	U	DF	P		
A	B	C	D	E	F	G	H	I	J
Series	Length	Lumen Output	CCT	CRI	Voltage	Lens	Latches	Optional Power	Optional End Controls

Catalog Logic:

A. Series

VGL = Vapor Guard LED

B. Length

2 = 2'
4 = 4'
8 = 8'

C. Lumen Output

M = Medium
H = High

D. CCT

45 = 4500K

E. CRI

85 = 85

F. Voltage

U = (120V-277V)
48 = 480V
UNB = (120V-277V) Non-Switching Battery Back-Up
USB = (120V-277V) Switching Battery Back-Up

G. Lens

DF = Deep Frosted Acrylic
RF = Ribbed Frosted Acrylic
DC = Deep Clear Acrylic
RC = Ribbed Clear Acrylic

H. Latches

P = Polycarbonate
S = Stainless Steel, Captive

I. Optional Power End

R3 = Mini-Receptacle, 3-wire, Male
P6 = 6' Yellow Lead, 3-wire, 16 AWG
R4 = Mini-Receptacle, 4-wire, Male
P6 = 6' Yellow Lead, 4-wire, 16 AWG

J. Optional Controls

MS = Wet Location Motion Sensor
MSD = Dry Location Motion Sensor
DMS = Dimming Motion Sensor (0-10V)

Performance Data

Catalog Number	Length	Lumen Output	Lens (Acrylic)	CCT	Actual Lumens	System Watts	Lumens per Watt	CRI
VGL2-M45-85-U-DF	2'	Medium	Deep Frosted	4500K	2,309	17	145	<i>84</i>
VGL2-H45-85-U-DF		High			3,385	25	140	<i>84</i>
VGL4-M45-85-U-DF	4'	Medium			7,090	55	130	<i>85</i>
VGL4-H45-85-U-DF		High			8,901	69	130	<i>85</i>
VGL8-M45-85-U-DF	8'	Medium			14,740	110	134	<i>85</i>
VGL8-H45-85-U-DF		High			17,100	139	123	<i>85</i>

* Numbers in italics are calculated using LED manufacturers data.

Consult factory for all available options & configurations.

Replacement Parts & Accessories

SF3-6	Mini-Connector, 3-wire, Female – 6'
SF4-6	Mini-Connector, 4-wire, Female – 6'
V-CL-4	Deep Clear Acrylic Lens – 4'
V-CLF-4	Deep Frosted Acrylic Lens – 4'
V-RL-4	Ribbed Clear Acrylic Lens – 4'
V-RLF-4	Ribbed Frosted Acrylic Lens – 4'
V-CL-8	Deep Clear Acrylic Lens – 8'
V-CLF-8	Deep Frosted Acrylic Lens – 8'
V-RL-8	Ribbed Clear Acrylic Lens – 8'
V-RLF-8	Ribbed Frosted Acrylic Lens – 8'
V-LP	Polycarbonate Latch 1 ea.
VG-PLK-4	Polycarbonate Latch Kit – 4'
VG-PLK-8	Polycarbonate Latch Kit – 8'
V-LS	Stainless Steel Captive Latch 1 ea.
VG-SLK-4	Stainless Steel Captive Latch Kit – 4'
VG-SLK-8	Stainless Steel Captive Latch Kit – 8'
V-MB2	Stainless Steel Mounting Bracket Kit
V-BAIL	Mounting Bushing (Bail) 1 ea.

Mounting Options

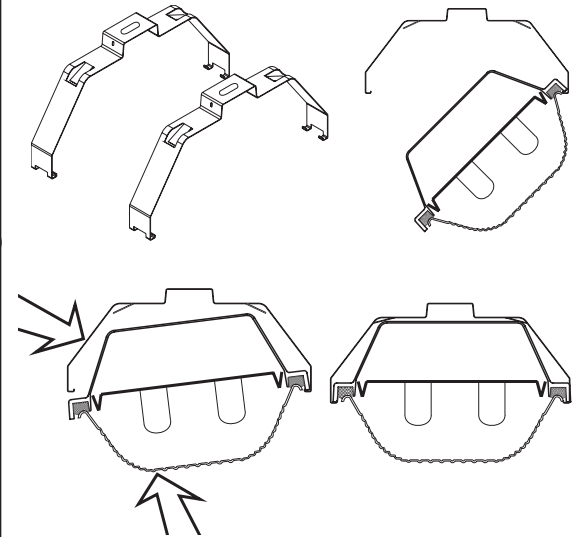

V-MB2
Provided as Standard)

