

# SEAL LITE

## Series



- Sealed Design for High Pressure Wash-Down Areas
- ETL Listed 1598 for Wet Location
- ETL Listed ANSI/NSF2
- Available in 2, 4, or 8-foot Models
- Exposed Areas are Non-Metallic or Stainless Steel
- Stainless Steel Mounting Hardware
- Chemical and Impact Resistant Acrylic Lens
- Quick Disconnects Available
- Battery Back-Up Models
- Mirror Reflectors Available
- Aluminum Interiors for Safety and Long Life
- High Pressure Tested to 1500 PSI



**LIGHTING ETC.**  
INCORPORATED

## Product Overview

The **SEAL LITE Series** utilizes the time tested and industry proven SEALED TUBULAR DESIGN to meet the rigorous demands and extreme conditions found in the daily operations of slaughterhouses and food processors. ETL listed UL 1598 for Wet Locations and pressure tested to 1500 PSI, the **SEAL LITE Series** complies with USDA sanitation and ANSI/ NSF2 splash zone requirements, making it the ideal choice for all types of meat or prepared food processing plants. Other applications include carwashes, bottling and canning plants, pharmaceutical plants or any industrial application requiring exposure to heavy hose-down and caustic chemicals.

## Dimensions

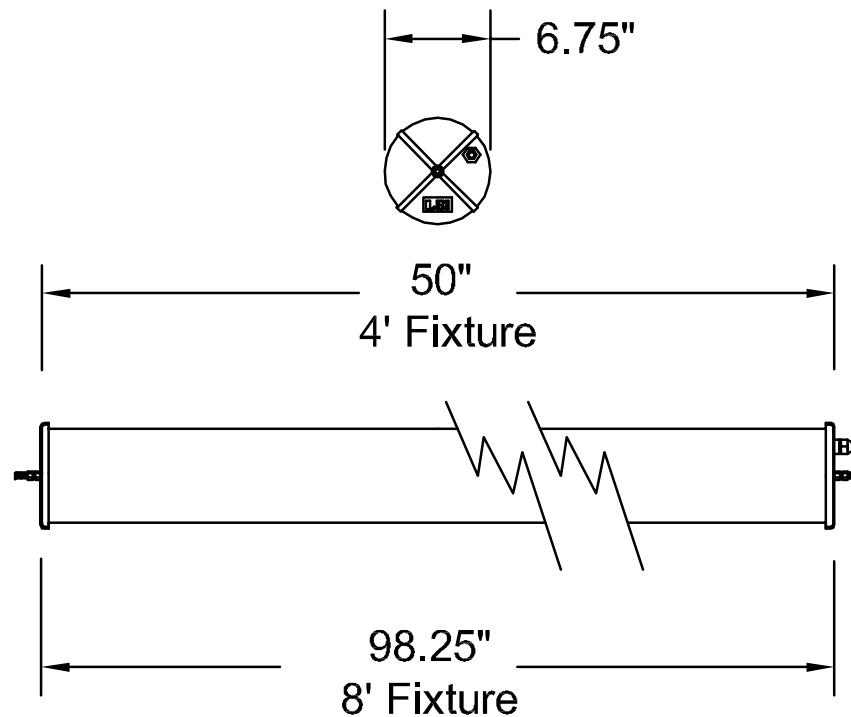

## Mounting Options

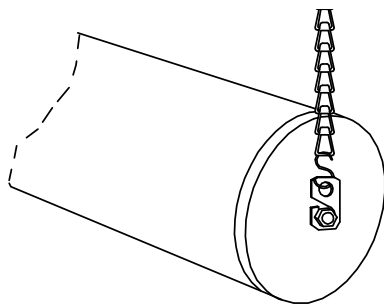

Chain

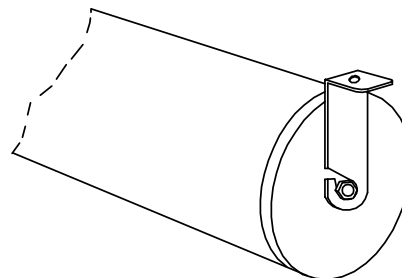

Fixed

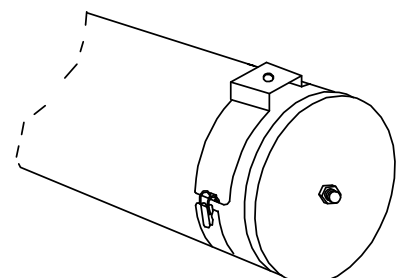

Band



**LIGHTING ETC.**  
INCORPORATED