

FLB Series



- Energy Saving Lamp & Ballast Configurations
- Universal Voltage (120V - 277V) Electronic Ballast
- Rugged 5VA Rated, Non-Metallic Housing
- Poured-in-Place, Closed Cell Gasket
- Stainless Steel Latches
- Stainless Steel Mounting Hardware
- Tool-Less Entry for Easy Installation & Maintenance
- ETL Listed UL 1598 for Wet Location
- ETL Listed CSA Std C22.2 No.250.0
- NSF Certified for Splash Zones
- IP65, IP66, IP67 Certified
- NEMA 4X Certified
- High Pressure Tested to 1500 PSI



LIGHTING ETC.
INCORPORATED

Product Overview

The **FLB Series** is an economy minded, energy saving luminaire designed with state-of-the-art lamp and ballast technology. The **FLB Series** is an excellent, energy saving alternative product to metal halide fixtures. Stainless steel latches assure the lens is properly sealed against the poured-in-place, closed cell gasket. Mounting is made easy with the supplied stainless steel "V" hooks or user-supplied cable mounting systems. Applications include food processing and cold storage facilities, dairies, bottlers or any area requiring exposure to water and dust.

Dimensions

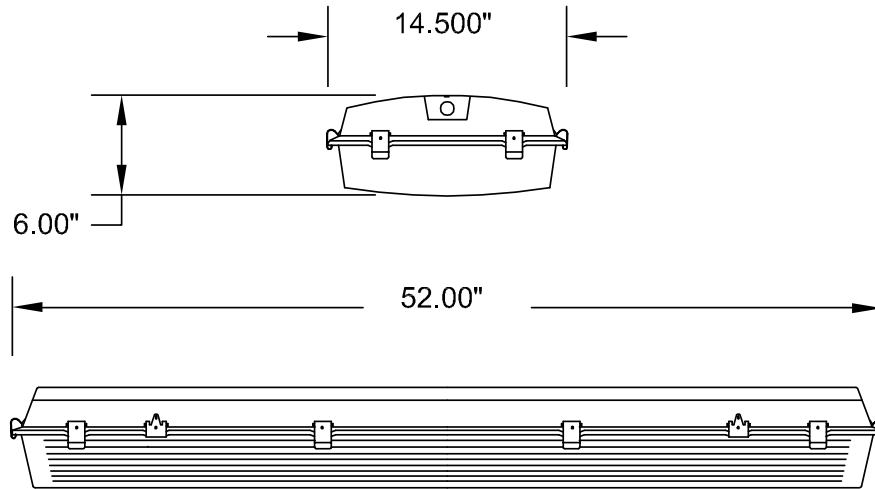

Mounting Options

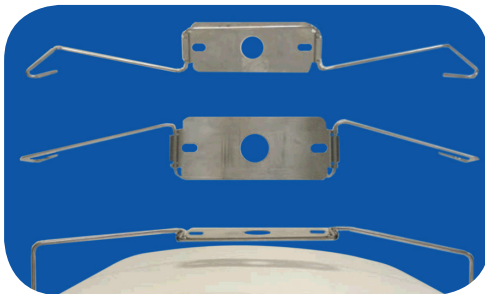

Ceiling Mount

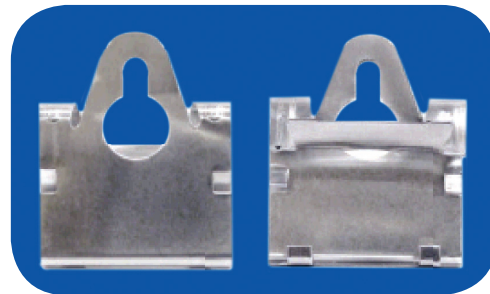

Universal Mounting Clip



V-Hook



Consult factory for all available options & configurations



LIGHTING ETC.
INCORPORATED